



2 Rickard Road Unanderra NSW

3 1 2

what you will love?
cottage | family | space

This beautiful cottage style home presents an amazing opportunity sitting on a sun-filled 1,005 m2 block, presenting a brilliant space and opportunity for you and your family. Nestled at the end of a large cul-de-sac leading to a view of the beautiful mountains at the top of the street and backing onto a reserve, the privacy it delivers is a must-see! The home itself has been a much-loved family home and is the perfect platform to start your property journey on.

+ polished floorboards throughout home sitting on a

[For full version visit the website](https://www.mcneice.com.au)

Type : House
Price : \$ 900,000
Land Size : 1005 sqm
View : <https://www.mcneice.com.au/8484538>



Danny Peterson
02 4284 8536

2 RICKARD ROAD, UNANDERRA

+ molenaar
mcneice

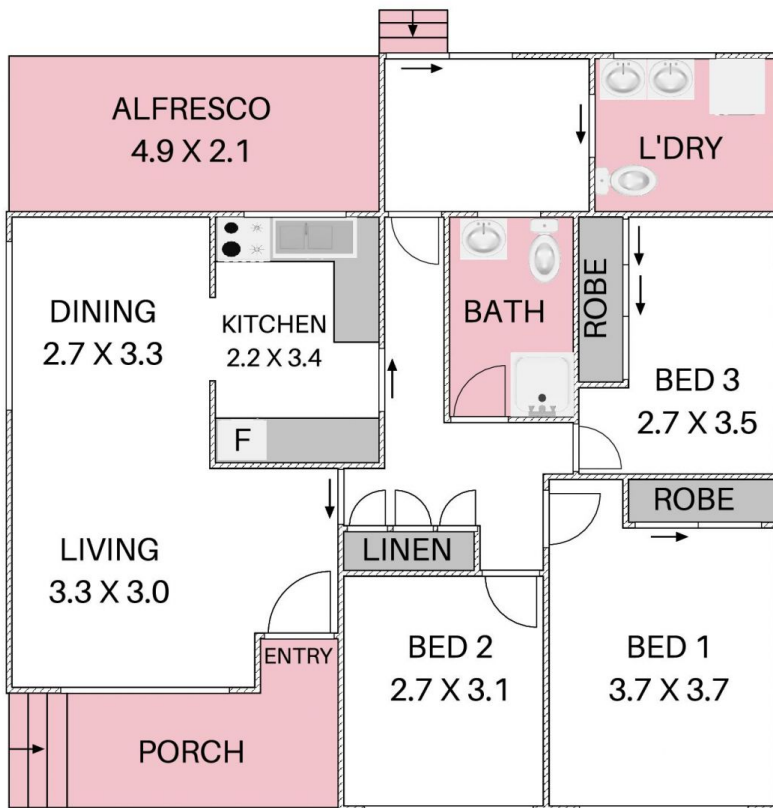
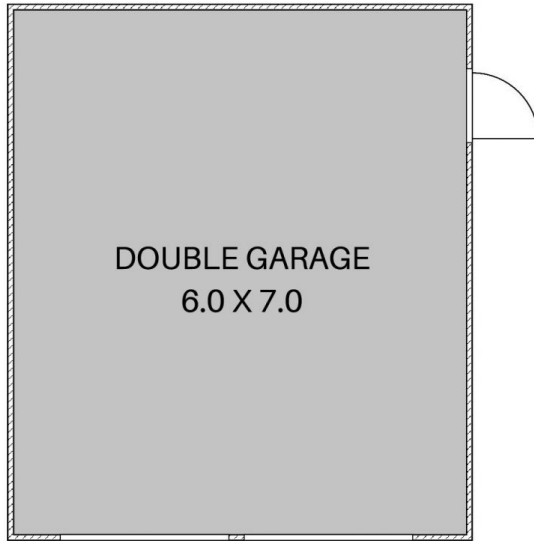

HOUSE TOTAL AREA 93m²
Plans shown are for presentation purposes and
are not part of any legal document.
Dimensions are approximate.

