



## 21 Greene Street Warrawong NSW

2 1

what you will love?  
bright | affordability | central | investment

Conveniently located within the centre of town is this bright single-level, two-bedroom home. Move-in ready the home has been neatly renovated and is the perfect offering for all buyers. Situated on a 759sqm parcel of land with over 18m frontage this large level block has ample scope for investors to capitalise on with an additional dwelling or spacious extension. \*\*To register for priority viewing contact the agent via phone or email to ensure you can view the property without delays.

+ living area flows to the generous sun-drenched yard

[For full version visit the website](#)

**Type** : House  
**Land Size** : 759 sqm  
**View** : <https://www.mcneice.com.au/8484177>



**Danny Peterson**  
02 4284 8536

21 GREENE STREET, WARRAWONG

+ molenaar  
mcneice

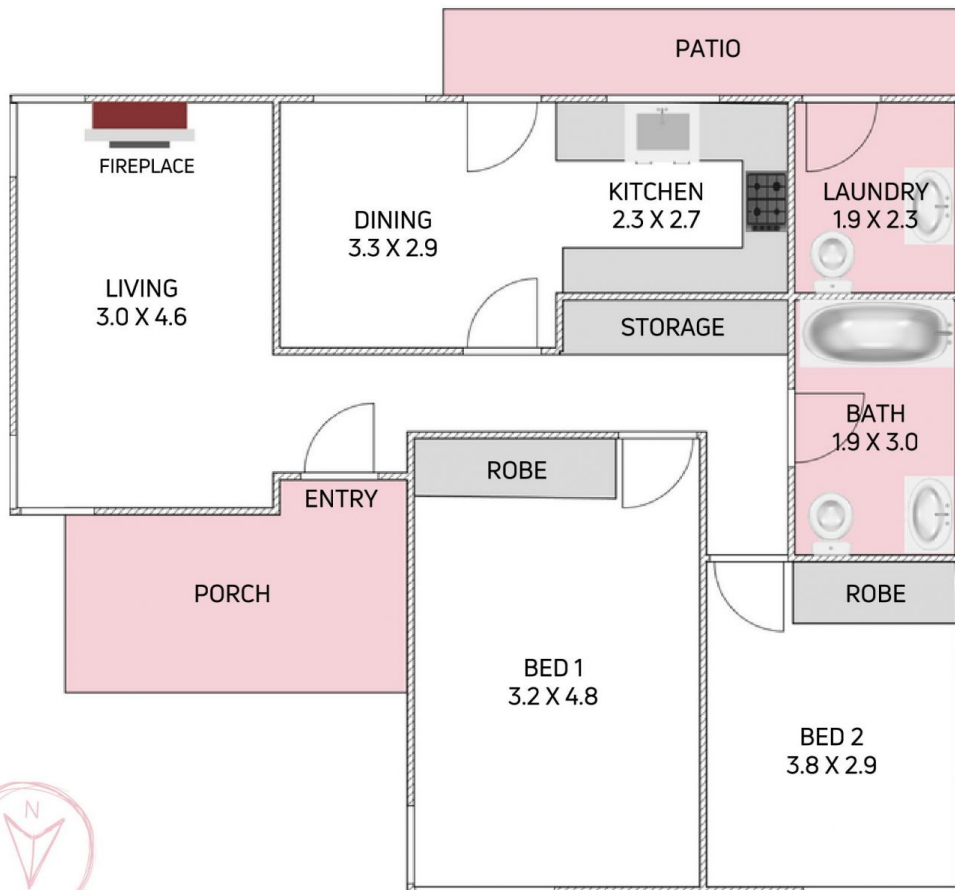
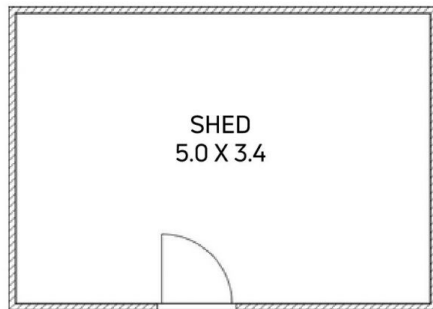

Plans shown are for presentation purposes and are not part of any legal document. Dimensions are approximate.