



14 Barellan Avenue Dapto NSW

4 1 2

This home's ability to effortlessly combine family living with convenience is what makes this home stand out

Spread over a level 683m² parcel of land with renovated interiors, manicured front gardens and a sunny north east facing outdoor alfresco entertainers deck which overlooks the pool and reserve at the rear, is this spacious, single level, 4 bedroom, energy efficient family home which will impress.

Features to highlight are an open plan layout, modern kitchen & bathroom, air conditioning, 27x solar panels to reduce electricity bills, multiple rainwater tanks, plantation shutters, gas heating & cooking, built in wardrobes in all

Type : House
Price : \$ 627,000
View : <https://www.mcneice.com.au/8482879>

[For full version visit the website](https://www.mcneice.com.au)

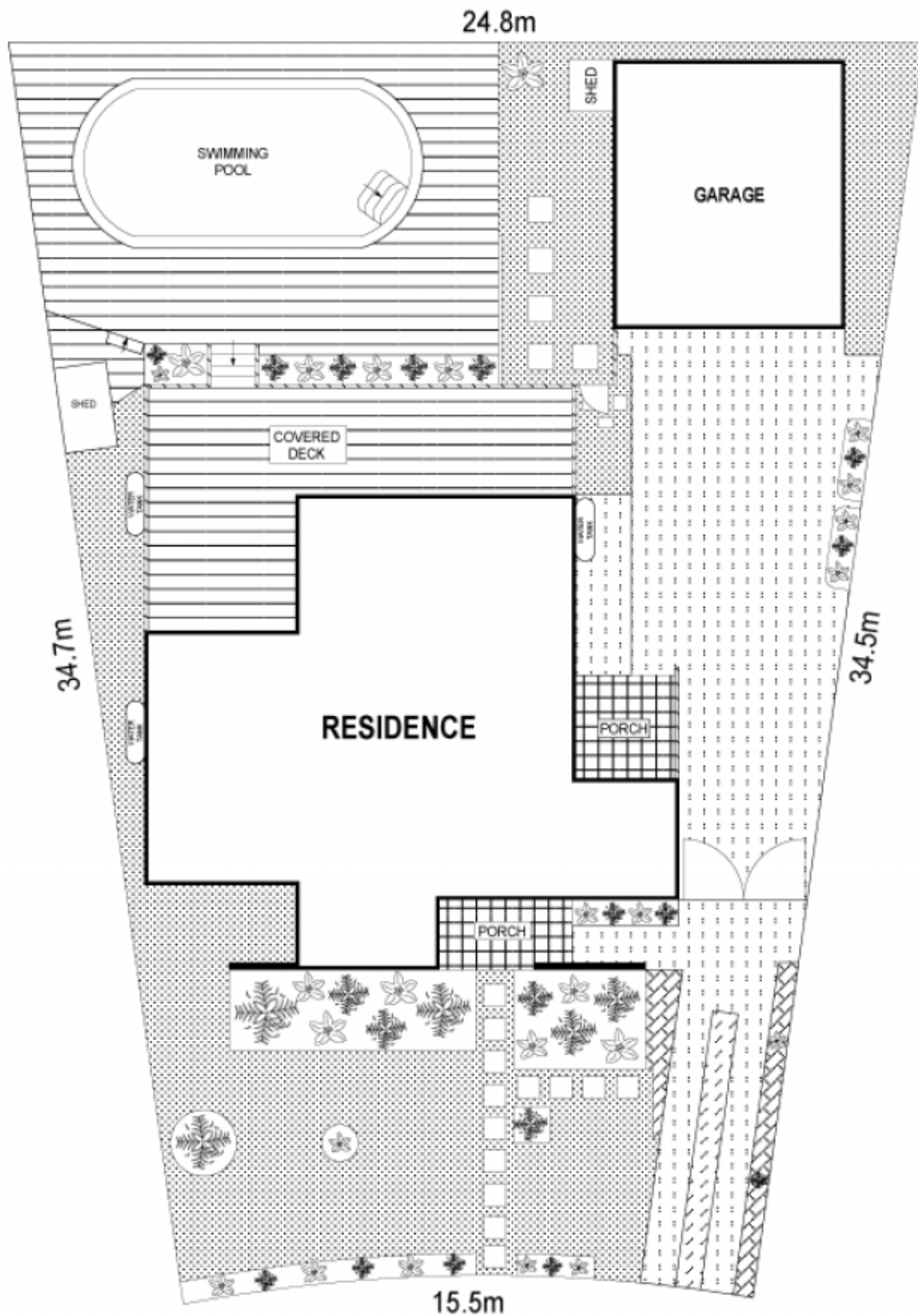

SITE PLAN



SCALE (METRES)

PLANS SHOWN ONLY INDICATIVE OF LAYOUT. DIMENSIONS ARE APPROXIMATE.
Ref No: 85576

14 BARELLAN AVENUE

DAPTO

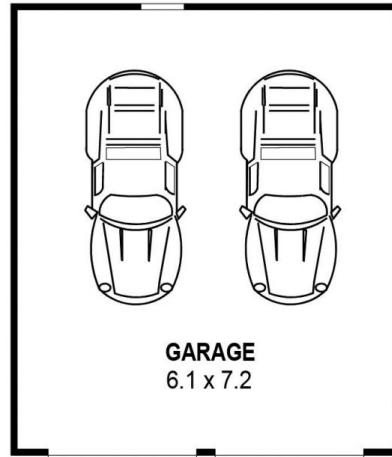

DETACHED

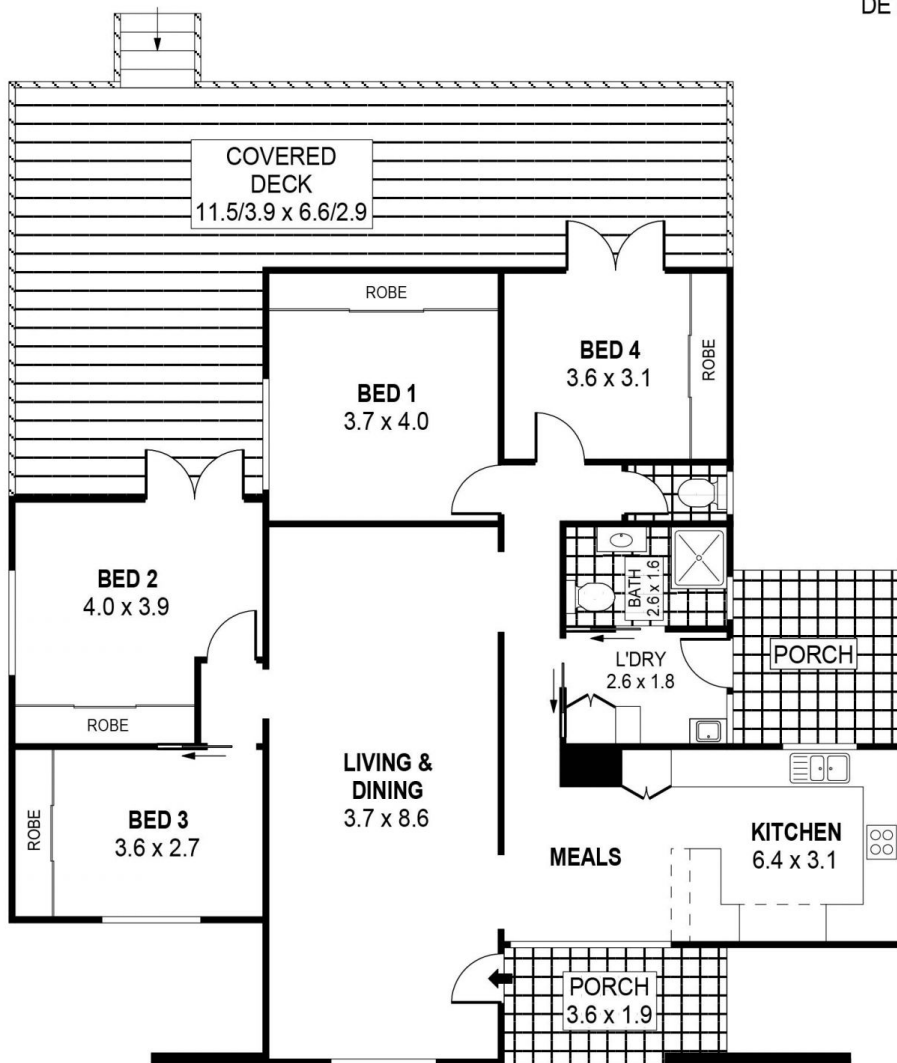

INT : 123m²
 EXT : 62m²
 GARAGE : 43m²

14 BARELLAN AVENUE

DAPTO

PLANS SHOWN ONLY INDICATIVE OF LAYOUT. DIMENSIONS ARE APPROXIMATE.
 Ref. No. 85576