



125 Compton Street Dapto NSW

3 1 1

125 Compton Street is perched on the high side of the street, encapsulating the incredible escarpment views. Accompanying that, the internal space and functional design is ideal for any first homeowner. Each area of the home is modern and in great condition. Outside sees a large undercover entertaining area with additional firepit area to the side of the home. The large garage is detached and accessible from Coronet Place.

Type : House
Price : \$ 575,000
Building Size : 15 sqm
View : <https://www.mcneice.com.au/8482840>

The Main Features:

- 3 spacious bedrooms all with built in wardrobes
- Large living space with bamboo flooring, built in cabinetry and reverse cycle air conditioner

[For full version visit the website](#)

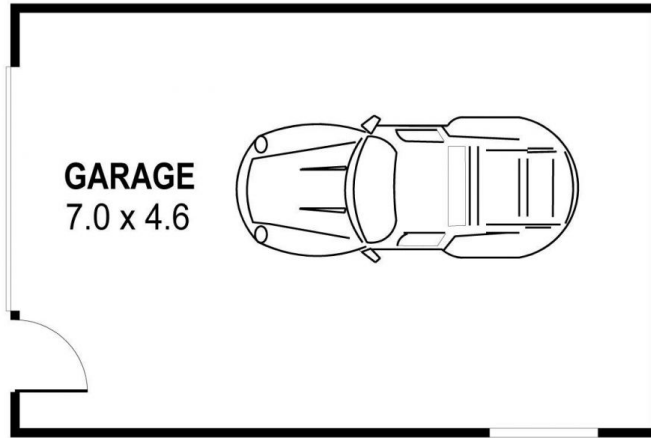

DETACHED

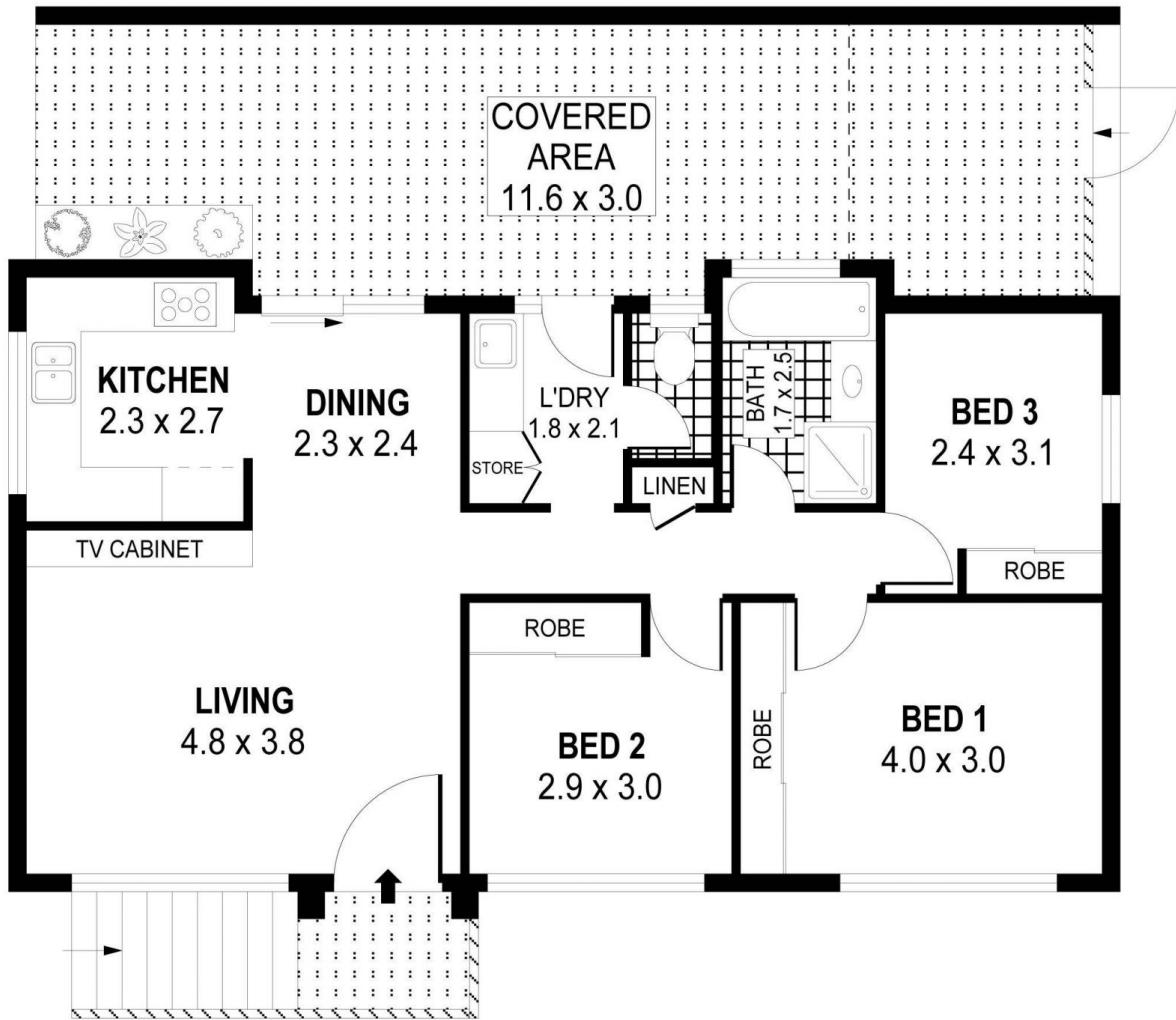

PLANS SHOWN ONLY INDICATIVE OF LAYOUT. DIMENSIONS ARE APPROXIMATE.
Ref. No: 79732

INT	: 75m ²
EXT	: 34m ²
GARAGE	: 32m ²

125 COMPTON STREET

DAPTO

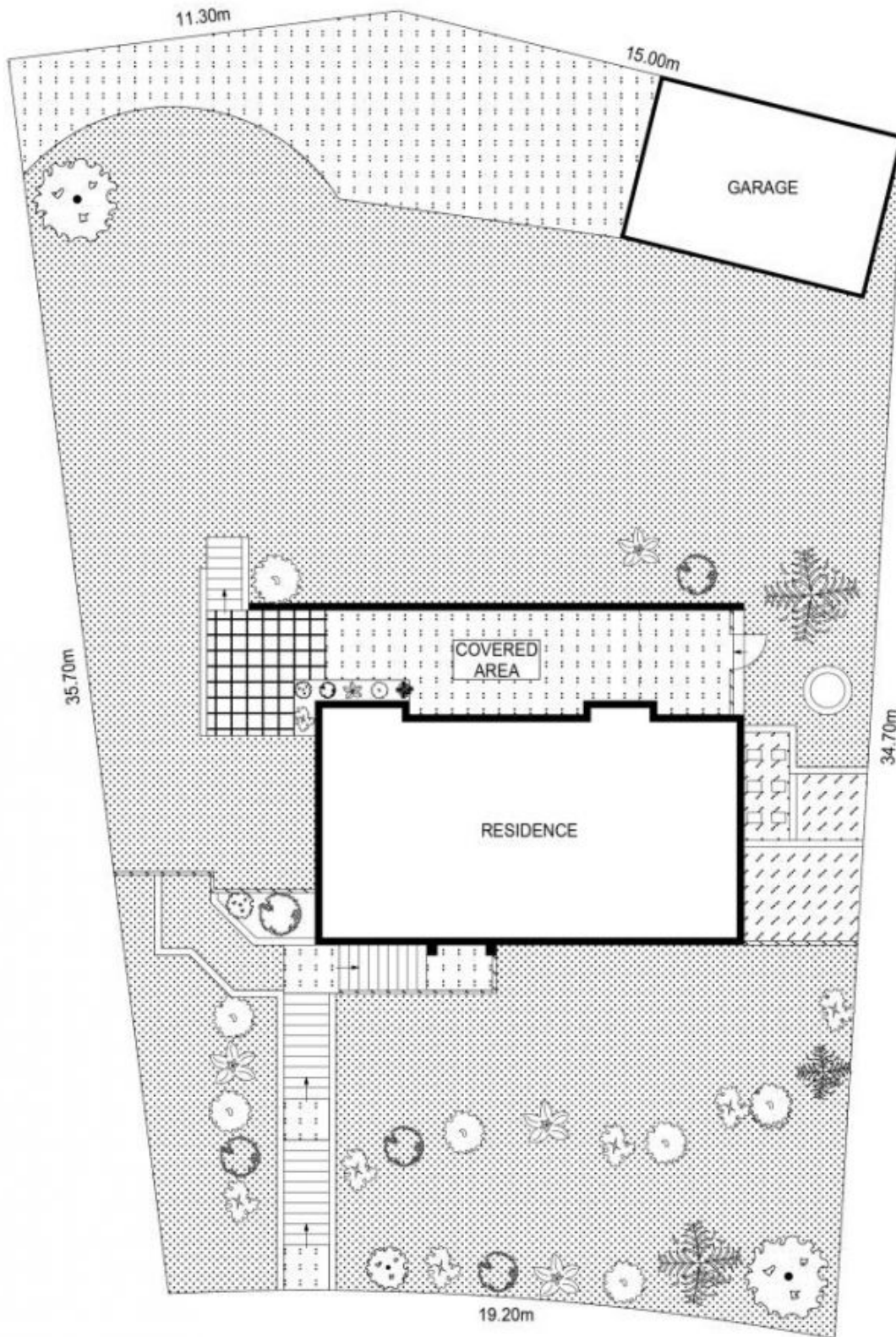

SITE PLAN



SCALE (METRES)

PLANS SHOWN ONLY INDICATIVE OF LAYOUT. DIMENSIONS ARE APPROXIMATE.
Ref. No. 79732

125 COMPTON STREET

DAPTO